

## Longs et extra-long

### Long and x-long

Largos y extra-largos

Lunghi ed extra lunghi

## Longs

Largos

Lunga

CARBURE CARBIDE  
Metallo duro



magafor standard

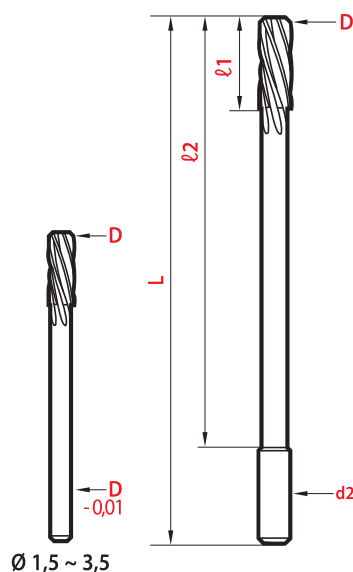

Nombre de lèvres Número de diente	Flute number Numero di taglienti
<b>Z</b>	<b>Ø</b>
4	1,0
6	1,5 ~ 12,0
8	13,0 ~ 20,0

H7 D	$\mu$ D 0,1 mm	L	l1	l2	d2 h6	H7 8680	$\mu$ 8685
1,0		50	12	30	D	113,09 €	
1,5		55	12	35	D	120,39 €	
2,0		65	14	45	D	108,23 €	
2,5		65	14	45	D	115,53 €	
3,0		90	14	70	D	100,93 €	
3,5		90	14	70	D	108,23 €	
	3,98 - 3,99	105	16	80	4		100,93 €
4,0	4,00	105	16	80	4	93,63 €	98,51 €
	4,01 - 4,02	105	16	80	4		100,93 €
4,5		105	16	80	4,5	108,23 €	
	4,98 - 4,99	115	16	90	5		100,93 €
5,0	5,00	115	16	90	5	103,37 €	108,23 €
	5,01 - 5,02	115	16	90	5		110,66 €
5,5		115	16	90	5,5	115,53 €	
	5,98 - 5,99	130	16	100	6		120,39 €
6,0	6,00	130	16	100	6	111,88 €	117,97 €
	6,01 - 6,02	130	16	100	6		120,39 €
6,5		130	16	100	6	145,94 €	
7,0		140	18	110	7	142,28 €	
7,5		140	18	110	7	164,17 €	
	7,98 - 7,99	160	18	130	8		169,04 €
8,0	8,00	160	18	130	8	156,87 €	165,39 €
	8,01 - 8,02	160	18	130	8		169,04 €
8,5		160	18	130	8	169,04 €	
9,0		175	18	140	9	164,17 €	
9,5		175	18	140	9	204,31 €	
	9,98 - 9,99	190	20	150	10		184,85 €
10,0	10,00	190	20	150	10	169,04 €	179,99 €
	10,01 - 10,02	190	20	150	10		184,85 €
10,5		190	20	150	10	226,20 €	
11,0		190	20	150	10	204,31 €	
11,5		220	22	170	12	263,90 €	
	11,98 - 11,99	220	22	170	12		244,44 €
12,0	12,00	220	22	170	12	226,20 €	239,57 €
	12,01 - 12,02	220	22	170	12		244,44 €
13,0		220	22	170	12	263,90 €	
14,0 - 15,0		220	22	170	12	324,70 €	
16,0		230	25	180	16	330,79 €	
18,0 - 20,0		230	25	180	16	411,06 €	

Ø 1,0 - 13,0 : Carbure monobloc Solid carbide Metal duro integral Metallo duro integrale

Ø 13,5 - 20 : Tête carbure brasée Cabeza metal duro soldada Brazed carbide head Testa in metallo duro saldobrasata

### Deux séries proposées / Two series are offered

Dos series son ofrecidas / Due tipologie proposte

<b>H7</b>	Ø 1,0 ~ 20,0 Tolérance Tolerancia Tolleranza <b>m5</b> .
$\mu$	autour des diamètres 4-5-6-8-10-12. Tolérance 0 / + 0,005 around the diameters 4-5-6-8-10-12. Tolerance 0 + 0,005 alrededor de los diámetros 4-5-6-8-10-12. Tolerancia 0 + 0,005 attorno ai diametri 4-5-6-8-10-12. Tolleranza 0 / + 0,005

## Longs

Largos  
Lunga

HSS-E COBALT



magafor standard

D H7	L	ℓ1	ℓ2	d2 h8	magafor 680
1,5	55	12	35	D	94,26 €
2,0	65	14	45	D	85,13 €
2,5	75	14	55	D	85,13 €
3,0	90	14	70	D	65,07 €
3,5	90	14	70	D	96,69 €
4,0	105	16	80	4	65,07 €
4,5	105	16	80	4,5	100,33 €
5,0	115	16	90	5	68,71 €
5,5	115	16	90	5,5	106,41 €
6,0	130	16	100	6	71,14 €
6,35 - 6,5	130	16	100	6	110,06 €
7,0	140	18	110	7	76,61 €
7,5	140	18	110	7	112,50 €
8,0	160	18	130	8	74,18 €
8,5	160	18	130	8	113,72 €
9,0	175	18	140	9	83,91 €
9,5	175	18	140	9	119,19 €
10,0	190	20	150	10	85,13 €
11,0	200	20	160	11	99,72 €
12,0	210	20	160	12	94,26 €

## Extra-long

Extra-largos  
Extra-lunga

HSS-E COBALT



magafor standard

D H7	L	ℓ1	ℓ2	d2 h8	magafor 683
1,5	65	15	45	D	134,99 €
2,0	80	20	60	D	134,99 €
2,5	100	25	80	D	138,65 €
3,0	120	30	100	D	142,28 €
3,5	140	30	120	D	170,27 €
4,0	160	30	135	4	139,85 €
4,5	180	30	155	4,5	178,77 €
5,0	200	30	175	5	150,81 €
5,5	220	30	195	5,5	179,99 €
6,0	250	35	220	6	153,23 €
7,0	250	35	220	7	182,43 €
8,0	250	35	220	8	156,87 €
9,0	250	35	220	9	188,50 €
10,0	250	35	220	10	161,75 €
12,0	295	40	250	12	199,00 €
14,0	295	40	250	14	219,00 €
16,0	320	45	270	16	229,00 €
18,0	320	45	270	16	239,00 €
20,0	320	45	270	16	259,00 €

## Super longs

Extra-largos  
Extra-lunga

CARBURE CARBIDE  
Metallo duro



L = 650 mm

magafor standard

D H7	L	ℓ1	ℓ2	d2* h8	magaforce 8688
10,0	650	35	600	10	931,02 €
12,0	650	40	600	10	960,12 €
14,0	650	45	600	12	989,21 €
16,0	650	50	600	12	1047,40 €
18,0	650	55	600	16	1251,07 €
20,0	650	60	600	16	1472,18 €

Tête carbure brasée Cabeza metal duro soldada  
Brazed carbide head Testa in metallo duro saldobrasata

\* queue avec 3 plats 3 flated shanks  
Mango con 3 planos Codolo con 3 piani

Queue **cône Morse** jusqu'à 50mm  
**Morse taper shank** up to 50 mm  
*Cono Morse hasta 50 mm*  
*Codolo conico Morse fino a 50mm*

> p. 165



Alésions longs spéciaux  
Special long reamers  
Escariadores especiales largos  
Alesatori speciali lunghi

> p. 170



## H7

### Standard

HSS-E COBALT

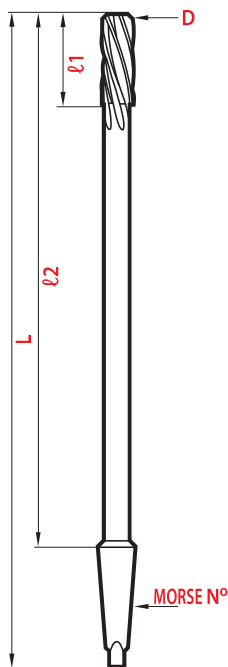

DIN 208-B • NFE 66015

D H7 inches	D H7 mm	L	l1	l2	MORSE N°	magafor 660
	4,0	120	19	54	1	79,04 €
	5,0	133	23	67	1	66,89 €
	6,0	138	26	72	1	54,73 €
	7,0	150	31	84	1	63,85 €
	8,0	156	33	90	1	57,77 €
	9,0	162	36	96	1	63,85 €
	10,0	168	38	102	1	57,77 €
	11,0	175	41	109	1	63,85 €
	12,0	182	44	116	1	60,80 €
12,7 (1/2")	12,5 - 13,0	182	44	116	1	66,89 €
	13,5 - 14,0	189	47	123	1	69,93 €
14,287 (9/16")	14,5 - 15,0	204	50	124	2	85,13 €
15,875 (5/8")	15,5 - 16,0	210	52	130	2	88,17 €
	16,5 - 17,0	214	54	134	2	94,26 €
	17,5 - 18,0	219	56	139	2	94,26 €
	18,5 - 19,0	223	58	143	2	106,41 €
19,05 (3/4")	19,5 - 20,0	228	60	148	2	106,41 €
	20,5 - 21,0	232	62	152	2	121,62 €
22,225 (7/8")	21,5 - 22,0	237	64	157	2	121,62 €
	22,5 - 23,0	241	66	161	2	160,53 €
	24 - 25	268	68	168	3	162,96 €
25,4 (1")	26	273	70	173	3	170,27 €
	27 - 28	277	71	177	3	194,58 €
	29 - 30 - 31	281	73	181	3	218,91 €
	32	290	77	190	3	255,39 €
	33 - 34 - 35	321	78	197	4	316,20 €
	36 - 37	329	81	205	4	456,05 €
	38 - 39 - 40	329	81	205	4	456,05 €
	41 - 42	336	83	212	4	504,70 €
	43 - 44 - 45	336	83	212	4	516,87 €
	46 - 47	344	86	220	4	638,48 €
	48 - 49 - 50	344	86	220	4	638,48 €
	55	344	86	220	4	1483,82 €
	60	344	86	220	4	1710,76 €

Nombre de lèvres / Número de diente      Flute number / Numero di taglienti

z	660 Ø	685 Ø	687 Ø
4	4,0 ~ 13,0		
6	13,5 ~ 25,0	13,0 ~ 25,0	13,0 ~ 25,0
8	25,4 ~ 38,0	26,0 ~ 38,0	26,0 ~ 38,0
12	39,0 ~ 60,0	40,0 ~ 50,0	40,0 ~ 50,0

performances

> p. 149



## Longs

Largos  
Lunga

HSS-E COBALT



magafor standard

D H7	L	ℓ1	ℓ2	MORSE N°	magafor 685
12,5 - 12,7	245	22	180	1	150,81 €
13	245	22	180	1	113,72 €
14	245	22	180	1	130,92 €
14	245	22	180	1	113,72 €
15	260	22	180	2	132,38 €
15	260	22	180	2	119,79 €
16	260	25	180	2	136,45 €
16	260	25	180	2	133,78 €
17	260	25	180	2	167,00 €
18	260	25	180	2	150,81 €
19	270	28	190	2	169,32 €
20	270	28	190	2	150,81 €
21	280	28	200	2	258,36 €
22	280	28	200	2	231,07 €
24	300	32	200	3	261,47 €
25	320	32	220	3	279,71 €
26	330	32	230	3	334,45 €
28	340	32	240	3	364,85 €
29	350	36	250	3	437,00 €
30	350	36	250	3	395,25 €
32	375	36	250	4	456,05 €
34	375	36	250	4	486,46 €
36	375	40	250	4	516,87 €
38	395	40	270	4	547,27 €
40	395	40	270	4	577,67 €
42	405	40	280	4	638,48 €
45	405	45	280	4	699,28 €
50	415	45	290	4	790,50 €

## Extra-longos

Extra-largos  
Extra-lunga

HSS-E COBALT



magafor standard

D H7	L	ℓ1	ℓ2	MORSE N°	magafor 687
12	315	40	250	1	197,01 €
14	315	40	250	1	215,25 €
16	350	45	270	2	224,97 €
18	350	45	270	2	243,52 €
20	350	45	270	2	257,82 €
22	350	45	270	2	346,60 €
24	450	70	350	3	395,25 €
25	450	70	350	3	419,56 €
26	450	70	350	3	486,46 €
28	450	70	350	3	535,10 €
30	450	70	350	3	577,67 €
35	475	70	350	4	729,69 €
40	475	70	350	4	851,30 €



# Special

Service dépannage

48 heures

Emergency

48-hour service

Servicio urgente 48 horas

Servizio emergenza 48 ore

> p. 170