



Alésoirs pour goupilles • Pin reamers

Escariadores para pasadores • Alesatori per spine coniche

Coniques à 2%

1:50 Taper

Cónicos a 2%

Conicità 2%

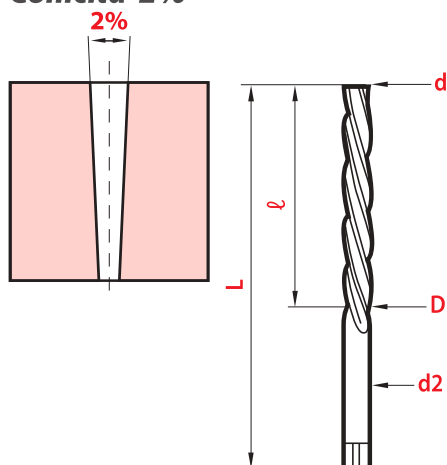

À main

Hand use

A mano

DIN 9 • NFE 66011

Type Tipo	Taille hélice Spiral flute Elicoidali		Taille Droite Straight flute Hélice recta		magafor 700		magafor 720	
Ø	d	D	L	ℓ	d2			
Nominal ± 0,05 ± 0,05								
0,8	0,7	1,2	42	24	1,2	66,89 €		
1,0	0,9	1,4	46	28	1,5	60,80 €		
1,2	1,1	1,7	50	32	1,8	54,73 €		
1,5	1,4	2,1	57	37	2,2	54,73 €	47,42 €	
2,0	1,9	2,8	72	48	3,1	45,61 €	41,34 €	
2,5	2,4	3,3	72	48	3,3	42,56 €	40,75 €	
3	2,9	4,0	80	58	4	39,52 €	40,13 €	
4	3,9	5,2	93	68	5	39,52 €	40,13 €	
5	4,9	6,3	100	73	6,3	42,56 €	41,34 €	
6	5,9	8,0	135	105	8	45,61 €	49,85 €	
7	6,9	9,4	160	125	9	66,89 €		
8	7,9	10,8	180	145	10	60,80 €	69,93 €	
9	8,9	12,1	195	160	11,2	91,21 €		
10	9,9	13,4	215	175	12,5	79,04 €	96,07 €	
12	11,8	16,0	255	210	14	115,53 €	131,34 €	
14	13,8	18,0	255	210	16	194,58 €		
16	15,8	20,4	280	230	18	176,33 €	204,31 €	
18	17,8	22,4	290	230	22,4	304,03 €		
20	19,8	24,8	310	250	22,4	243,23 €		
22	21,8	26,8	320	250	26,8	456,05 €		
25	24,7	30,7	370	300	28	395,25 €		
28	27,7	33,7	380	300	33,7	790,50 €		
30	29,7	36,1	400	320	36,1	729,69 €		
40	39,7	46,5	430	340	40	1124,94 €		
50	49,7	56,9	460	360	50	1702,60 €		

À machine

Machine use

Máquina

A macchina

DIN 2180 • NFE 66010

Type Tipo	Hélice Spiral Elica 45°						magafor 711	
Ø	d	D	L	ℓ	d2			
Nominal ± 0,05 ± 0,05								
2,0	1,9	2,86	86	48	3,15	51,49 €		
2,5	2,4	3,36	86	48	3,15	54,11 €		
3	2,9	4,06	100	58	4	54,98 €		
4	3,9	5,26	112	68	5	56,04 €		
5	4,9	6,36	122	73	6,3	57,90 €		
6	5,9	8,0	160	105	8	60,80 €		
8	7,9	10,8	207	145	10	92,23 €		
10	9,9	13,4	245	175	12,5	130,92 €		
12	11,8	16,0	290	210	16	170,19 €		

À machine

Machine use

Máquina

A macchina

DIN 2180 • NFE 66010

Type Tipo	Hélice Spiral Elica 45°						MORSE N°		magafor 731	
Ø	d	D	L	ℓ	MORSE N°					
Nominal ± 0,05 ± 0,05										
5	4,9	6,36	155	73	1	113,47 €				
6	5,9	8	187	105	1	119,29 €				
8	7,9	10,8	227	145	1	136,21 €				
10	9,9	13,4	257	175	1	143,50 €				
12	11,8	16	315	210	2	162,96 €				
16	15,8	20,4	335	230	2	262,02 €				
20	19,8	24,8	377	250	3	402,54 €				
25	24,7	30,7	427	300	3	611,56 €				
30	29,7	36,1	475	320	4	891,44 €				
40	39,7	46,5	495	340	4	1353,57 €				
50	49,7	56,9	550	360	5	2127,04 €				



Ce type d'alésoir est indispensable aux moulistes pour exécuter des buses d'injection de façon rationnelle.
Les alésoirs taille droite avec brise-copeaux sont recommandés pour obtenir des trous coniques impeccables: ils évitent tout phénomène de reproduction.

This type of taper reamer is indispensable to mould makers for making injection nozzles in a rational fashion.
The straight flute taper reamers with chipbreaker are recommended when faultless conical holes are desired: It is then possible to avoid any special copying phenomenon.

Los escariadores corte recto con rompevirutas están recomendados para obtener agujeros cónicos perfectos. Estos evitan el efecto de reproducción de la hélice.
Este tipo de escariadores es indispensable para los moldistas: para efectuar de manera apropiada el agujero de inyección.

Questo tipo di alesatore è indispensabile agli stampisti per la realizzazione, in modo appropriato, dei fori di iniezione.
Gli alesatori a taglienti dritti con rompitruciolo sono consigliati per realizzare dei fori conici perfetti: Eliminano ogni fenomeno di riproduzione dell'elica.



magafor standard

D ± 0,05	d ± 0,05	L	ℓ	d2 h8	magafor 740	magafor 745
2	1	50	20	2		133,78 €
4	2	80	40	4		145,94 €
6	3	110	60	6	91,21 €	161,75 €
8	4	130	80	8	125,25 €	190,28 €
10	5	155	100	10	149,58 €	229,55 €
12	6	180	120	12	214,43 €	290,37 €
14	7	200	140	14	233,51 €	344,18 €
16	8	260	160	Morse 2	366,59 €	
18	9	278	180	Morse 2	373,35 €	

D ± 0,05	d ± 0,05	L	ℓ	d2 h8	magafor 750	magafor 755
6	2	100	50	6	75,40 €	132,55 €
8	3	110	62	8	91,21 €	161,75 €
10	4	130	75	10	106,41 €	188,82 €
12	5	150	90	12	137,42 €	240,79 €
14	6	160	100	14	200,66 €	
16	7	210	112	Morse 2	301,61 €	
18	8	223	125	Morse 2	344,16 €	
20	9	236	137	Morse 2	443,89 €	

D ± 0,05	d ± 0,05	L	ℓ	d2 h8	magafor 760	magafor 765
4	1,5	65	25	4	98,05 €	
6	2	90	40	6	75,40 €	120,39 €
8	3	100	50	8	91,21 €	148,37 €
10	4	115	60	10	106,41 €	161,75 €
12	5	130	70	12	137,42 €	193,38 €
14	6	140	80	14	200,66 €	330,79 €
16	7	190	90	Morse 2	248,09 €	
20	9	210	110	Morse 2	373,35 €	
25	12	250	130	Morse 3	537,54 €	
30	14	280	160	Morse 3	895,09 €	

Pour buses d'injection

Para boquillas de inyección
Per fori di iniezione

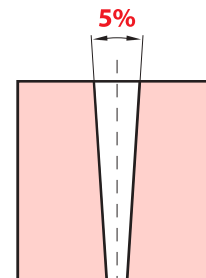
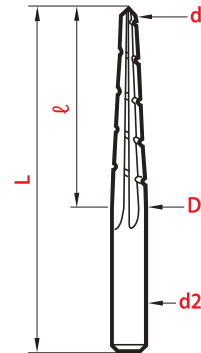

CONICITÉ 5% TAPER
CONICIDAD 1:20 CONICITA'

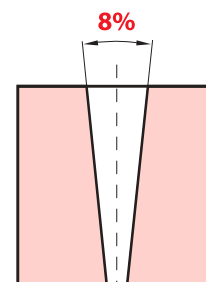

CONICITÉ 8% TAPER
CONICIDAD 2:25 CONICITA'

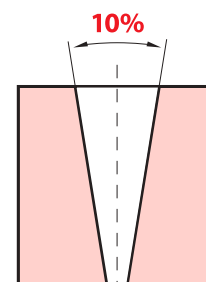

CONICITÉ 10% TAPER
CONICIDAD 1:10 CONICITA'



Machine pour cônes morse

Machine for morse taper holes

Máquina para conos morse

A macchina per coni morse

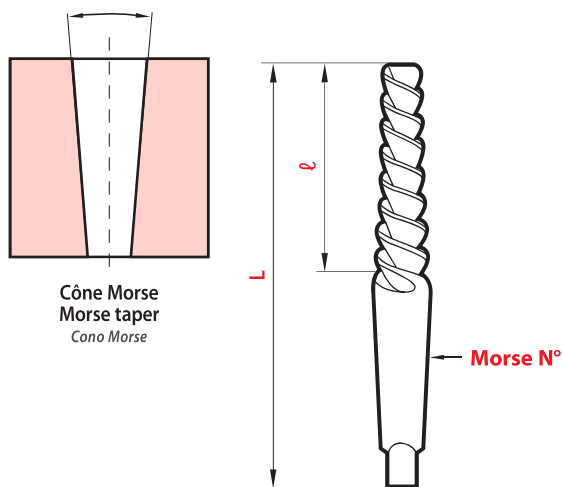

HSS

DIN 1895-D

Alésoir pour CM N° Reamer for MT N° Esc. para CM N°	L	ℓ	MORSE N°	magafor 780
0	137	61	1	144,71 €
1	142	66	1	147,15 €
2	173	79	2	201,89 €
3	212	96	3	287,02 €
4	263	119	4	452,40 €
5	331	150	5	1083,59 €

À main coniques gaz 6,25%

Hand NPT - NPTF 1:16 Gas

Mano cónicos gas 6,25%

Mano conicita' gas 6,25% (1:16)

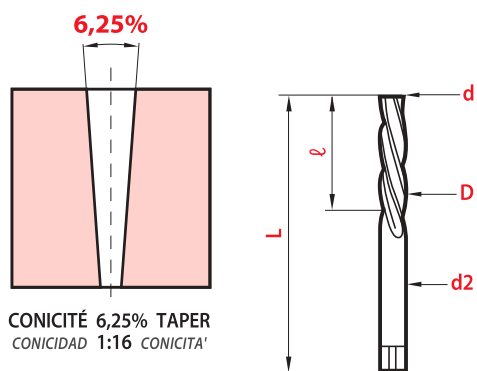

HSS

Ø Nominal	d	D	L	ℓ	d2	magafor 785
1/8"	7,9	9,2	59	22	8	160,53 €
1/4"	10,7	12,1	67	23	10	183,63 €
3/8"	14,0	15,6	75	26	12,5	220,12 €
1/2"	17,2	19,3	87	34	16	250,53 €
3/4"	22,7	24,8	96	34	20	277,29 €
1"	28,4	30,8	109	39	25	347,82 €
1-1/2"	43,1	45,72	125	42	35,5	549,00 €