



Forets à pointer NC • NC spotting drill

Brocas de puntear • Punte a centrare

Courts Short

Cortas
Corte

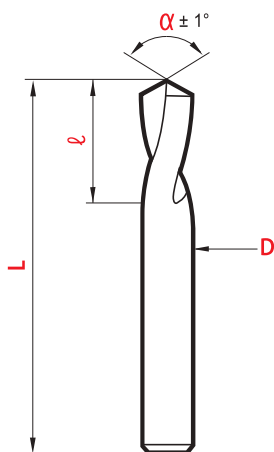
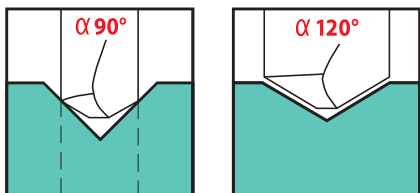

Angle 90°: on obtiendra centrage et chanfreinage en une seule opération.

Angles 120°: L'avant-trou obtenu correspond à l'angle en bout de l'outil de perçage et évite à celui-ci de dévier.

90 degree angle: centering and chamfering are obtained in a single operation.

120 degree angle: The preliminary hole corresponds to the angle at the end of the tool used in drilling and prevents it from deviating.

Ángulo 90°: obtendrá un centrado y avellanado en una sola operación.

Ángulo de 120°: El agujero previo obtenido corresponde al ángulo de la punta de la herramienta utilizada para taladrar y previene su desvío.

Angolo 90°: si otterrà la centratura e lo smusso in un'unica operazione.

Angolo 120°: l'avanzoro realizzato corrisponde all'angolo di affilatura dell'utensile a forare impedendo a quest'ultimo di deviare.

Autres types Other types

Otros tipos
Altri tipi

avec plat • with flats
con piano

> p. 38

extra courts • extra shorts
extra corta

> p. 40

HSS 8% Co
α 142°

> p. 38

cône morse • morse taper shank
mango cono Morse

> p. 41

coupe à gauche • left hand cut
corte a izquierdas • elica sinistra

> p. 40

longs
largas lunghe

> p. 42

Micro-NC

magafor standard

90°

CARBURE CARBIDE
Metallo duro



D +0,01	ℓ	magaforce 819-D	Hard'X 819-DH
0,3*	0,9	49,85 €	55,95 €
0,4	1,2	45,61 €	51,68 €
0,5	1,5	41,65 €	46,51 €
0,6	1,8	38,92 €	43,78 €
0,7	2,1	38,92 €	43,78 €
0,8	2,4	38,92 €	43,78 €
0,9	2,7	38,92 €	43,78 €
1,0	3,0	38,92 €	43,78 €
1,2	3,6	38,92 €	43,78 €
1,5	4,5	38,92 €	43,78 €
2,0	6,0	38,92 €	43,78 €
2,5	7,5	38,92 €	43,78 €

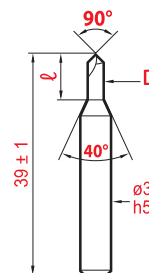

Tolérances

ℓ	
Ø 0,3 ~ 0,5	0,15
Ø 0,6 ~ 0,8	0,2
Ø 0,9 ~ 2,5	0,3

* Pointage à partir de 0,05 Spotting from 0,05 Centrado desde 0,05 Centratura da 0,05

CARBURE CARBIDE
Metallo duro



CARBURE CARBIDE
Metallo duro



magafor standard

90°

120°

90°

120°

D h5	L ± 1	ℓ +2	magaforce 8195	magaforce 8196	Hard'X 8195-H	Hard'X 8196-H
2,0	40	8	27,36 €	27,36 €	31,02 €	31,02 €
3,0	45	10	24,33 €	24,33 €	27,96 €	27,96 €
3,17 (1/8")	45	10	24,33 €		27,96 €	
4,0	50	12	29,18 €	29,18 €	32,83 €	32,83 €
4,76 (3/16")	50	15	34,06 €		37,69 €	
5,0	50	15	34,06 €	34,06 €	37,69 €	37,69 €
6,0	50	18	38,92 €	38,92 €	42,56 €	42,56 €
6,35 (1/4")	50	18	42,56 €	42,56 €	46,22 €	46,22 €
7,93 (5/16")	60	23	54,73 €		59,58 €	
8,0	60	23	54,73 €	54,73 €	59,58 €	59,58 €
9,52 (3/8")	70	24	80,26 €	80,26 €	85,13 €	85,13 €
10,0	70	24	81,48 €	81,48 €	86,35 €	86,35 €
12,0	70	24	114,32 €	114,32 €	121,62 €	121,62 €
12,70 (1/2")	70	24	124,04 €	124,04 €	132,55 €	132,55 €
14,0	75	24	169,04 €	169,04 €	179,99 €	179,99 €
15,87 (5/8")	80	26	192,15 €	192,15 €	201,89 €	201,89 €
16,0	80	26	193,38 €	193,38 €	203,10 €	203,10 €
20,0	100	35	350,26 €	350,26 €	363,62 €	363,62 €

Performances
 > p. 17

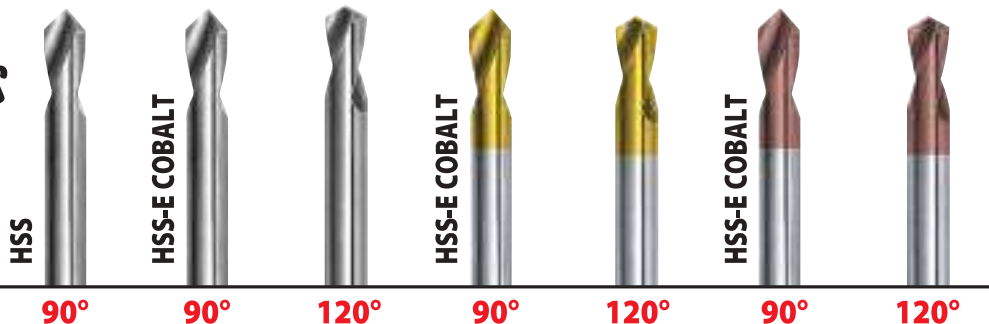

NFE 66052 • ISO 10898

D h6*	L ± 1	ℓ +1	classic 190*	magafor 195	magafor 196	TIN 0895	TIN 0896	Red'X 0995	Red'X 0996
2,0	49	8		15,20 €	15,20 €	20,06 €	20,06 €	21,28 €	21,28 €
3,0	50	10	9,61 €	12,65 €	12,65 €	17,02 €	17,02 €	18,24 €	18,24 €
3,17 (1/8")	50	10		12,89 €	12,89 €	17,28 €	17,28 €	18,48 €	18,48 €
4,0	52	12	9,97 €	13,14 €	13,14 €	18,00 €	18,00 €	19,21 €	19,21 €
4,76 (3/16")	60	15		14,11 €	14,11 €	18,97 €	18,97 €	20,19 €	20,19 €
5,0	60	15	10,71 €	14,23 €	14,23 €	19,10 €	19,10 €	20,44 €	20,44 €
6,0	66	20	11,31 €	14,60 €	14,60 €	21,16 €	21,16 €	22,49 €	22,49 €
6,35 (1/4")	66	22		16,72 €	16,72 €	23,34 €	23,34 €	24,68 €	24,68 €
7,93 (5/16")	79	25		17,94 €		25,24 €		26,75 €	
8,0	79	25	13,68 €	17,94 €	17,94 €	25,24 €	25,24 €	26,75 €	26,75 €
9,52 (3/8")	89	25		20,06 €	20,06 €	28,69 €	28,69 €	30,64 €	30,64 €
10,0	89	25	14,89 €	20,31 €	20,31 €	29,08 €	29,08 €	31,02 €	31,02 €
12,0	102	30	21,28 €	27,96 €	27,96 €	40,13 €	40,13 €	42,56 €	42,56 €
12,70 (1/2")	102	35		29,80 €	29,80 €	41,95 €	41,95 €	43,78 €	43,78 €
14,0	115	35		39,82 €	39,82 €	55,33 €	55,33 €	58,37 €	58,37 €
15,87 (5/8")	115	35		40,13 €	40,13 €	57,77 €	57,77 €	60,80 €	60,80 €
16,0	115	35	31,62 €	40,75 €	40,75 €	58,08 €	58,08 €	62,02 €	62,02 €
18,0	130	40		75,40 €	75,40 €	98,51 €	98,51 €	104,59 €	104,59 €
19,05 (3/4")	131	40		77,83 €	77,83 €	102,16 €	102,16 €	109,45 €	109,45 €
20,0	131	40	60,21 €	78,44 €	78,44 €	102,16 €	102,16 €	109,45 €	109,45 €
25,0	138	45		109,45 €	109,45 €	139,85 €	139,85 €	149,58 €	149,58 €
25,4 (1")	138	45		119,19 €	119,19 €	149,58 €	149,58 €	159,31 €	159,31 €

* Code 190 = h7

Video on line



magafor *Le choix! The choice! La elección! La scelta!*

www.magafor.com

Matière Material Materiale	HSS	HSS-E COBALT	HSS-E COBALT + TiN	HSS-E COBALT + Red'X	CARBURE CARBIDE Metallo duro	CARBURE CARBIDE + Hard'X
Dureté Hardness Durezza	63 HRC	65 HRC	65 HRC + 2300 HV	65 HRC + 3500 HV	1800 HV	1800 HV + 3500 HV
Utilisation Use Utilización Impiego	Petites séries Small series Pequeñas series Piccole serie	Production intensive Intensive production Producción intensiva Produzione intensiva		Alliages durs et abrasifs Hard and abrasive alloys Aleaciones duras y abrasivos Leghe dure e abrasive		Aciers trempés Treated steels Aceros tratados Acciai temprati
Page Pagina	> 37-40-43	> 37 ~ 43	> 37-41-43	> 36-39-42		

Promo-kits



magafor

Type Tipo	classic 190	magafor 195 196	Tin 0895 0896	Red'X 0995 0996	magaforce 8195 8196	Hard'X 8195-H 8196-H
1 pièce 1 piece 1 pieza 1 pezzo			Ø 4 - 5 - 6 - 8 - 10 - 12			
	83,00 €	106,33 €	152,03 €	160,53 €	352,68 €	380,65 €

magafor

Centrage • Pointage / Centering • Spotting
 Centraturo • Centraturo NC / Centrato • Punteado



Forets à pointer NC • NC spotting drill

Brocas de puntear • Punte a centrare

Courts Short

Cortas

Corte

NFE 66052 • ISO 10898

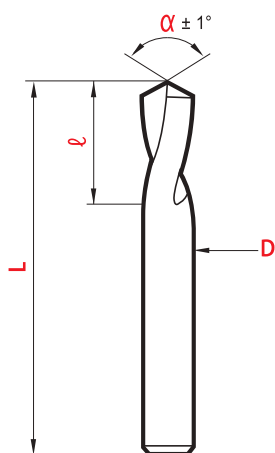
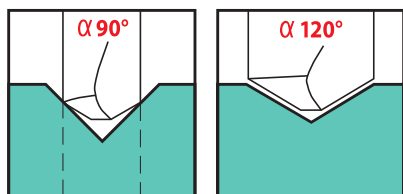

HSS 8% Co

			HSS 8% COBALT		HSS 8% COBALT		HSS 8% COBALT	
			90°	120°	90°	120°	90°	120°
D	L	ℓ	magafor 19-J	magafor 19-K	TIN 089-J	TIN 089-K	Red'X 099-J	Red'X 099-K
h6	± 1	+ 1						
3,0	50	10	15,20 €	15,20 €	20,06 €	20,06 €	21,28 €	21,28 €
4,0	52	12	15,80 €	15,80 €	20,68 €	20,68 €	21,90 €	21,90 €
5,0	60	15	17,02 €	17,02 €	22,49 €	22,49 €	23,71 €	23,71 €
6,0	66	20	18,24 €	18,24 €	24,93 €	24,93 €	26,15 €	26,15 €
8,0	79	25	21,59 €	21,59 €	29,18 €	29,18 €	30,71 €	30,71 €
10,0	89	25	24,33 €	24,33 €	32,23 €	32,23 €	34,06 €	34,06 €
12,0	102	30	33,75 €	33,75 €	46,22 €	46,22 €	48,64 €	48,64 €
16,0	115	35	49,85 €	49,85 €	68,11 €	68,11 €	72,06 €	72,06 €
20,0	131	40	95,17 €	95,17 €	120,39 €	120,39 €	127,69 €	127,69 €

DIN 6535 HB Avec méplat de serrage With flat

Con plano

Attacco Weldon

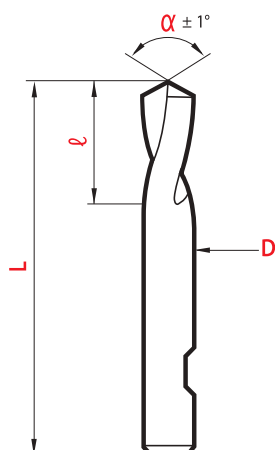

HSS-E COBALT

			HSS-E COBALT		HSS-E COBALT		HSS-E COBALT	
			90°	120°	90°	120°	90°	120°
D	L	ℓ	magafor 195-W	magafor 196-W	TIN 0895-W	TIN 0896-W	Red'X 0995-W	Red'X 0996-W
h6	± 1	+ 1						
6,0	66	20	17,51 €	17,51 €	25,42 €	25,42 €	27,00 €	27,00 €
8,0	79	25	21,53 €	21,53 €	30,28 €	30,28 €	32,11 €	32,11 €
10,0	89	25	24,33 €	24,33 €	34,91 €	34,91 €	37,23 €	37,23 €
12,0	102	30	33,57 €	33,57 €	48,16 €	48,16 €	51,08 €	51,08 €
16,0	115	35	48,90 €	48,90 €	69,70 €	69,70 €	74,42 €	74,42 €
20,0	131	40	93,63 €	93,63 €	122,59 €	122,59 €	131,34 €	131,34 €



142°

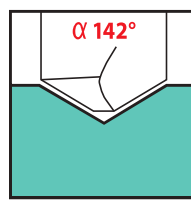

New 2024

Pour les alliages durs, l'angle à 142° prépositionne les trous, avant utilisation de forets à 135° ou 140°. Deux qualités proposées : HSS-E Cobalt et carbure monobloc. Pour les alliages fortement abrasifs la gamme **8190-H** est préconisée.

En aleaciones de alta dureza el ángulo de 142° debe usarse para la operación de punteado antes de usar brocas con 135° ó 140°. Disponibles en dos calidades: HSS-E Cobalto y Metal Duro. Para aleaciones abrasivas recomendamos la referencia **8190-H**.

In hard alloys the 142° angle has to be used for the spotting operation before the 135° or 140° twist drills. Two qualities are offered: HSS-E Cobalt and solid carbide. For abrasive alloys the **8190-H** range is recommended.

Per lavorazioni su leghe dure l'angolo a 142° consente il corretto posizionamento della punta preposta alla foratura avente angolo di 135° o 140°. Due sono le tipologie offerte: HSS-E e metallo duro. La gamma **8190-H** è raccomandata nelle lavorazioni di leghe fortemente abrasive.

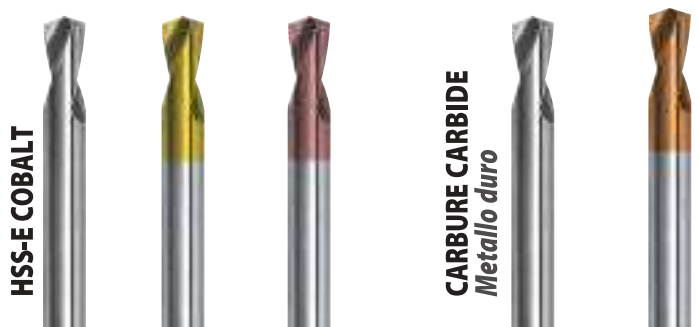
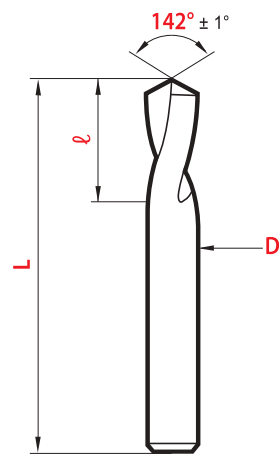

D		L	ℓ	142°			142°		
h7*	± 1	+1	magafor 194	TIN 0894	Red'X 0994	L ± 1	ℓ +1	magaforce 8190	Hard'X 8190-H
2,0						40	8	30,54 €	34,06 €
3,0	50	10	16,43 €	20,68 €	22,49 €	45	10	27,52 €	31,02 €
4,0	52	12	17,63 €	21,90 €	23,71 €	50	12	32,41 €	35,87 €
5,0	60	15	18,85 €	23,71 €	24,93 €	50	15	37,25 €	40,75 €
6,0	66	20	19,46 €	26,15 €	27,36 €	50	18	41,49 €	44,99 €
6,35 (1/4")	66	20	21,58 €	28,33 €	29,54 €	50	18	45,16 €	48,64 €
8,0	79	25	23,71 €	31,02 €	32,83 €	60	23	58,54 €	63,24 €
9,52 (3/8")	89	25	25,83 €	34,47 €	36,72 €	70	24	84,21 €	90,00 €
10,0	89	25	26,75 €	35,87 €	37,69 €	70	24	86,46 €	91,21 €
12,0	102	30	36,49 €	49,25 €	51,68 €	70	24	120,68 €	127,69 €
12,7 (1/2")	102	30	38,33 €	50,97 €	52,90 €	70	24	130,46 €	138,65 €
15,87 (5/8")	115	35	54,11 €	71,44 €	74,18 €	80	26	201,05 €	210,39 €
16,0	115	35	54,73 €	71,75 €	75,40 €	80	26	202,32 €	211,61 €
20,0	131	40	104,59 €	128,91 €	134,99 €				

Hard-X
Jusqu'à
up to
Hasta
Fino a 67 HRC

* CARBURE CARBIDE METAL DURO METALLO DURO = h5



Forets à pointer NC • NC spotting drill

Brocas de puntear • Punte a centrare

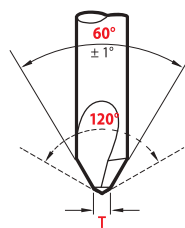
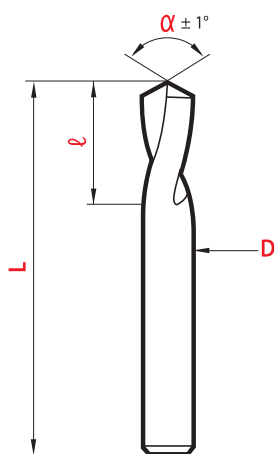
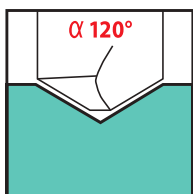
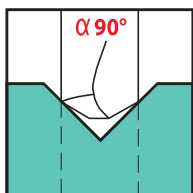
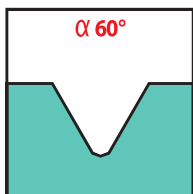

HSS-E COBALT

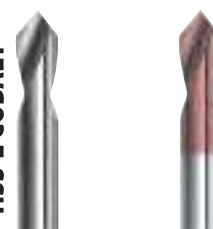

60°

magafor standard

α 60°

D x d	L	ℓ	T*	magafor 191	Red'X 0991
h6	± 1	+1			
4,0	52	12	0,8	54,73 €	60,80 €
5,0	60	15	0,9	57,77 €	63,85 €
6,0	66	20	1,0	60,80 €	69,93 €
8,0	79	25	1,3	63,85 €	76,01 €
10,0	89	25	1,6	66,89 €	82,10 €
12,0	102	30	2,0	72,97 €	91,21 €
16,0	115	35	3,0	109,45 €	136,81 €
20,0	131	40	3,5	182,43 €	224,97 €

*T = angle ángulo Angulo 120°

Coupe à gauche

Left hand cut

Corte a izquierdas

Elica sinistra

HSS-E COBALT



magafor standard

α 90°

90°

120°

D x d	L	ℓ	magafor 192	Red'X 0992	magafor 193
h6	± 1	+1			
3,0	50	10	30,41 €	36,49 €	30,41 €
4,0	52	12	36,49 €	42,56 €	36,49 €
5,0	60	15	42,56 €	48,64 €	42,56 €
6,0	66	20	48,64 €	57,77 €	48,64 €
8,0	79	25	54,73 €	66,89 €	54,73 €
10,0	89	25	60,80 €	76,01 €	60,80 €
12,0	102	30	72,97 €	91,21 €	
16,0	115	35	115,53 €	142,90 €	

Extra courts

Extra short

Extra cortas

Extra corta

HSS



D h7		L	ℓ	classic 19-A	classic 19-B	classic 19-AG	classic 19-BG
inch	mm	± 1	+1				
1/8"	3,17	32	9,5	10,94 €	10,94 €	18,16 €	18,16 €
3/16"	4,76	35	12,5	12,16 €	12,16 €	20,19 €	20,19 €
1/4"	6,35	38	16	14,29 €	14,29 €	23,74 €	23,74 €
5/16"	7,93	38	16	15,20 €	15,20 €	25,26 €	25,26 €
3/8"	9,52	51	25,5	17,02 €	17,02 €	28,28 €	28,28 €
7/16"	11,11	51	25,5	20,98 €	20,98 €		
1/2"	12,7	51	25,5	25,24 €	25,24 €	41,90 €	41,90 €
5/8"	15,87	57	28,5	34,35 €	34,35 €	57,13 €	57,13 €
3/4"	19,05	57	28,5	69,93 €	69,93 €	116,08 €	116,08 €
7/8"	22,22	64	32	94,26 €	94,26 €		
1"	25,4	64	32	103,99 €	103,99 €	172,59 €	172,59 €

Queue cône Morse

Morse taper shank

Mango
Cono Morse

HSS-E COBALT

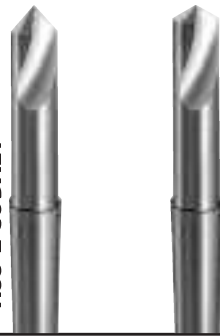

90°

106°

D	L	ℓ1	ℓ2	MORSE	magafor	magafor
h10	± 1	+1	+1	N°	198	1906
10,0	130	25	64	1	102,76 €	
12,0	130	30	64	1	107,62 €	119,79 €
16,0	148	35	68	2	132,55 €	148,37 €
20,0	148	40	68	2	158,10 €	176,33 €
25,0	171	45	72	3	217,69 €	240,79 €

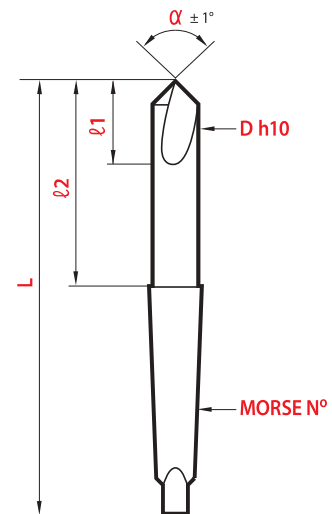

COMBI-mag

Outils multi-fonctions

multi-function tools

Herramientas multi-función
Utensili multi-funzione

HSS-E COBALT



90°

COMBI-mag

D h7	L	ℓ	T*	Red'X	
inch	mm	± 1	+1	007	
	3	50	6	0,3	18,85 €
1/8"	3,17	50	6	0,3	18,85 €
	4	52	8	0,4	19,46 €
3/16"	4,76	60	9	0,5	20,06 €
	5	60	10	0,5	20,06 €
	6	66	12	0,6	23,71 €
1/4"	6,35	66	12	0,6	24,93 €
5/16"	7,93	79	14	0,8	27,67 €
	8	79	14	0,8	27,67 €
3/8"	9,52	89	16	1	31,62 €
	10	89	16	1	32,83 €
	12	102	18	1,2	42,56 €
1/2"	12,7	102	19	1,3	44,99 €
	14	115	21	1,4	60,21 €
5/8"	15,87	115	24	1,6	62,64 €
	16	115	24	1,6	62,64 €

*T = 0,1 D Épaisseur d'âme Web thickness Espesor del núcleo Spessore in punta del nocciolo

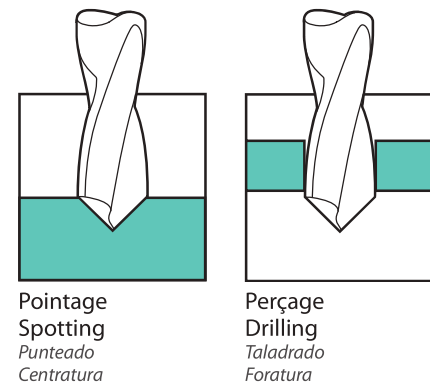

Pointage
Spotting
Punteado
Centraturo

Perçage
Drilling
Taladrado
Foratura

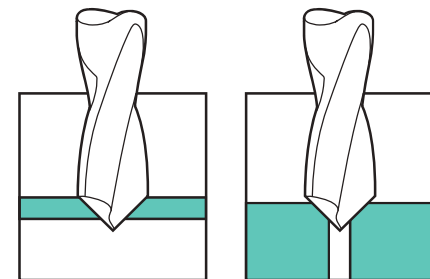

Chanfrein direct
Direct chamfer
Chañlanes directos
Svasatura rapida

Chanfreinage
Chamfering
Chañlanado
Sbavatura

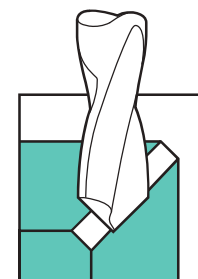

Chanfrein longitudinal
Longitudinal chamfer
Chañlanes longitudinales
Smussi longitudinali

Promo-kits



6 COMBI-mag Ø 4 - 5 - 6 - 8 - 10 - 12
007 166,61 €

Forets à pointer NC • NC spotting drill

Brocas de puntear • Punte a centrare

Longs Long

Largas
Lunghe

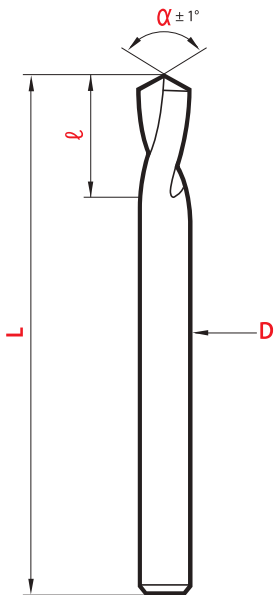
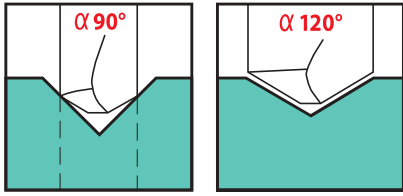

magafor standard			90°	120°	90°	120°
D	L	ℓ	magaforce 8197	magaforce 8199	Hard'X 8197-H	Hard'X 8199-H
h5	± 1	+1				
1,0	50	6	88,17 €		91,83 €	
2,0	60	8	72,97 €		76,61 €	
3,0	80	10	79,04 €		82,70 €	
4,0	100	12	91,21 €	91,21 €	94,86 €	94,86 €
5,0	120	15	97,29 €	97,29 €	100,93 €	100,93 €
6,0	140	20	109,45 €	109,45 €	114,32 €	114,32 €
6,35 (1/4")	140	22	121,62 €	121,62 €	126,48 €	126,48 €
8,0	140	25	133,78 €	133,78 €	138,65 €	138,65 €
9,52 (3/8")	170	25	224,97 €	224,97 €	231,07 €	231,07 €
10,0	170	25	231,07 €	231,07 €	237,14 €	237,14 €
12,0	170	30	291,87 €	291,87 €	301,00 €	301,00 €
12,70 (1/2")	170	35	304,03 €	304,03 €	313,16 €	313,16 €
15,87 (5/8")	200	35	437,81 €	437,81 €	449,98 €	449,98 €
16,0	200	35	437,81 €	437,81 €	449,98 €	449,98 €
19,05 (3/4")	200	40	668,88 €	668,88 €	684,08 €	684,08 €
20,0	200	40	699,28 €	699,28 €	714,49 €	714,49 €

Hard-X Jusqu'à up to Hasta Fino a 67 HRC

De dureté à chaud élevée (3500 HV), ce revêtement présente une très grande stabilité thermique et une excellente protection contre la chaleur et l'usure. Idéal pour les usinages à sec - à très grande vitesse - dans les aciers traités et matrices.

With a high hardness (3500 HV), this coating shows a high thermal stability and an excellent protection against heat and wear. Ideal for dry machining - high speed cut - in treated steels and dies.

Con una alta durezza (3500 HV) este recubrimiento proporciona una alta estabilidad térmica y una excelente protección contra el calor y el desgaste. Ideal para mecanizado en seco - a alta velocidad - en aceros tratados y de matrices.

Con notevole durezza a caldo (3500 HV) questo rivestimento presenta una grande stabilità termica ed un'eccellente protezione contro il calore e l'usura. Ideale per le lavorazioni a secco - a velocità elevate - negli acciai trattati e nelle matrici.

magafor *Le choix! The choice! La elección! La scelta!*

Matière Material Materiale	HSS	HSS-E COBALT	HSS-E COBALT + Red'X	CARBURE CARBIDE Metallo duro	CARBURE CARBIDE + Hard'X
Dureté Hardness Durezza	63 HRC	65 HRC	65 HRC + 2300 HV	1800 HV	1800 HV + 3500 HV
Utilisation Use Utilización Impiego	Petites séries Small series Pequeñas series Piccole serie	Production intensive Intensive production Producción intensiva Produzione intensiva		Aciers trempés Treated steels Aceros tratados Acciai temprati	
Page Pagina	➤ 37-40-43		➤ 37~ 43		➤ 36-39-42

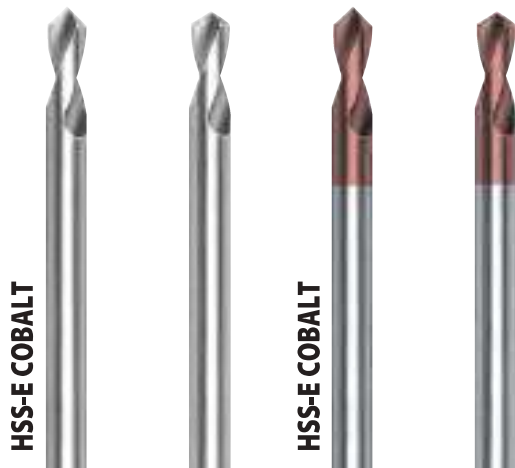

magafor standard			90°	120°	90°	120°
D	L	ℓ	magafor 197	magafor 199	Red'X 0997	Red'X 0999
h6	± 1	+1				
1,0	50	6	57,77 €	57,77 €	62,64 €	62,64 €
2,0	60	8	48,64 €	48,64 €	58,37 €	58,37 €
3,0	80	10	42,56 €	42,56 €	47,42 €	47,42 €
4,0	100	12	39,52 €	39,52 €	44,39 €	44,39 €
5,0	120	15	42,56 €	42,56 €	47,42 €	47,42 €
6,0	140	20	45,61 €	45,61 €	50,47 €	50,47 €
6,35 (1/4")	140	22	48,64 €	48,64 €	54,73 €	54,73 €
8,0	140	25	51,68 €	51,68 €	58,98 €	58,98 €
9,52 (3/8")	170	25	69,93 €	69,93 €	78,44 €	78,44 €
10,0	170	25	72,97 €	72,97 €	82,70 €	82,70 €
12,0	170	30	90,00 €	90,00 €	100,93 €	100,93 €
12,70 (1/2")	170	35	93,63 €	93,63 €	104,59 €	104,59 €
15,87 (5/8")	200	35	130,92 €	130,92 €	140,52 €	140,52 €
16,0	200	35	133,25 €	133,25 €	142,86 €	142,86 €
19,05 (3/4")	200	40	167,87 €	167,87 €	185,33 €	185,33 €
20,0	200	40	171,66 €	171,66 €	191,45 €	191,45 €
25,4 (1")	200	45	215,88 €	215,88 €		

Performances
 ➤ p. 17

Red-X
 Jusqu'à
 up to
 Hasta
 Fino a 55 HRC



α				90°	120°
D h7	L	ℓ	classic 19-C	classic 19-D	
inch	mm	± 1	+1		
1/4"	6,35	66 (2-5/8")	22	13,37 €	13,37 €
		102 (4")	22	34,65 €	34,65 €
		140 (5-1/2")	22	42,88 €	42,88 €
3/8"	9,52	79 (3")	25	16,12 €	16,12 €
		127 (5")	25	54,73 €	54,73 €
		178 (7")	25	67,49 €	67,49 €
1/2"	12,7	95 (3-3/4")	35	24,02 €	24,02 €
		152 (6")	35	67,49 €	67,49 €
		203 (8")	35	84,52 €	84,52 €
5/8"	15,87	111 (4-3/8")	35	32,52 €	32,52 €
		200 (8")	35	113,47 €	113,47 €
		229 (9")	35	142,56 €	142,56 €
3/4"	19,05	127 (5")	40	62,33 €	62,33 €
		200 (8")	40	148,38 €	148,38 €
		254 (10")	40	177,48 €	177,48 €
1"	25,4	138 (5-7/16")	45	95,46 €	95,46 €
		200 (8")	45	190,58 €	190,58 €
		254 (10")	45	229,55 €	229,55 €



HSS



Centrage • Pointage / Centering • Spotting
 Centratúra • Centratúra NC / Centrado • Punteado