



Forets à centrer • Center drills

Brocas de centrar • Punta a centrare

60°

Avec bourrelet de renfort Forme W With reinforcing bulge Form W

Con refuerzo Forma W

Con refuerzo Forma W

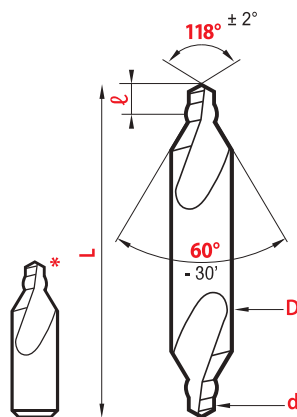
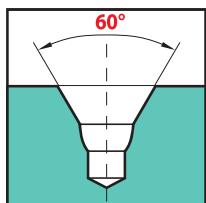

Le foret à centrer **magafor** forme W est plus robuste qu'un foret à centrer normal :

- le bourrelet renforce la pointe,
- il augmente le dégagement des copeaux,
- il favorise la lubrification du foret.

The **magafor** center drill form W is stronger than common center drills:

- the bulge reinforces the point,
- it improves swarf removal,
- it makes the lubrication of the drill easier.

La broca de centrar **magafor** forma W es més robusta que qualquier broca de centrar estàndar:

- Punta reforzada,
- Aumento de evacuación de viruta,
- Mejor lubricación de la broca.

La punta a centrare **magafor** forma W è più robusta di una punta a centrare normale:

- il bordino rinforza la punta,
- migliora l'evacuazione dei trucioli,
- favorisce la lubrificazione della punta.

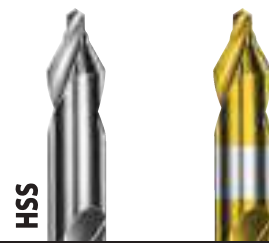

ISO • NFE 66051-W
DIN 333-W • JIS-1

HSS

TIN
0814

D x d	L	ℓ	magafor 14	TIN 0814
h7 k12	± 1	mini maxi		
3,0 x 0,5	31	0,6 ~ 0,9	12,29 €	
3,15 x 0,5*	25	0,6 ~ 0,9	6,08 €	
3,15 x 0,8*	25	1,0 ~ 1,3	6,08 €	
3,15 x 1,0	31	1,3 ~ 1,7	6,08 €	
3,15 x 1,25	31	1,6 ~ 2,0	6,08 €	
4,0 x 1,0	35	1,3 ~ 1,7	6,56 €	12,83 €
4,0 x 1,25	35	1,6 ~ 2,0	6,56 €	
4,0 x 1,6	35	2,0 ~ 2,6	6,56 €	
5,0 x 1,5	40	2,0 ~ 2,6	7,18 €	13,94 €
5,0 x 1,6	40	2,0 ~ 2,6	7,18 €	
5,0 x 2,0	40	2,5 ~ 3,1	7,18 €	
6,0 x 2,0	45	2,5 ~ 3,1	7,90 €	15,20 €
6,3 x 2,0	45	2,5 ~ 3,1	7,90 €	
6,3 x 2,5	45	3,1 ~ 3,8	7,90 €	
8,0 x 2,5	50	3,1 ~ 3,8	8,64 €	16,54 €
8,0 x 3,0	50	3,9 ~ 4,6	8,64 €	
8,0 x 3,15	50	3,9 ~ 4,6	8,64 €	
10,0 x 3,0	55	3,9 ~ 4,6	11,31 €	21,34 €
10,0 x 3,15	55	3,9 ~ 4,6	11,31 €	
10,0 x 4,0	55	5,0 ~ 5,9	11,31 €	
12,0 x 4,0	63	5,0 ~ 5,9	19,15 €	38,31 €
12,0 x 5,0	63	6,3 ~ 7,2	19,15 €	
12,5 x 4,0	63	5,0 ~ 5,9	19,15 €	
12,5 x 5,0	63	6,3 ~ 7,2	19,15 €	
14,0 x 5,0	69	6,3 ~ 7,2	25,54 €	
16,0 x 5,0	71	6,3 ~ 7,2	28,28 €	
16,0 x 6,3	71	8,0 ~ 8,9	28,28 €	
18,0 x 6,0	77	8,0 ~ 8,9	37,09 €	
20,0 x 6,3	80	8,0 ~ 8,9	57,16 €	
20,0 x 8,0	80	10,1 ~ 11,1	57,16 €	
25,0 x 10,0	100	12,8 ~ 13,8	90,00 €	

*D'un seul côté Single end De una sola punta Ad un solo lato

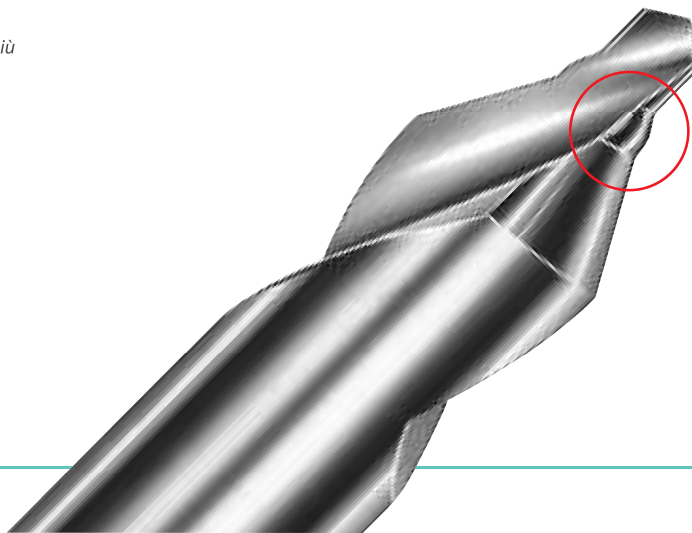



HSS



ASA N°	D x d h7 k12	L ± 1	ℓ mini maxi	magafor 145
1 - W	3,17 x 1,19 (1/8 x 3/64)	31	1,4 ~ 1,7	10,94 €
2 - W	4,76 x 1,98 (3/16 x 5/64)	47	2,4 ~ 2,7	10,94 €
3 - W	6,35 x 2,77 (1/4 x 7/64)	50	3,3 ~ 3,9	10,94 €
4 - W	7,93 x 3,17 (5/16 x 1/8)	54	3,8 ~ 4,4	12,47 €
5 - W	11,11 x 4,76 (7/16 x 3/16)	70	5,9 ~ 6,5	20,68 €
6 - W	12,70 x 5,55 (1/2 x 7/32)	76	6,9 ~ 7,5	23,11 €
7 - W	15,87 x 6,35 (5/8 x 1/4)	82	8,0 ~ 8,6	33,44 €
8 - W	19,05 x 7,93 (3/4 x 5/16)	89	10,0 ~ 10,6	60,21 €

ISO • NFE 66051-BW
DIN 333-BW • JIS-1

HSS



D x d h7 k12	L ± 1	K js13	ℓ mini maxi	magafor 023
6,3 x 1,6	45	3,3	2,0 ~ 2,6	12,04 €
8,0 x 2,0	50	4,2	2,5 ~ 3,1	13,85 €
10,0 x 2,5	55	5,3	3,1 ~ 3,8	17,38 €
11,2 x 3,15	62	6,7	3,9 ~ 4,6	25,30 €
14,0 x 4,0	69	8,5	5,0 ~ 5,9	35,87 €
18,0 x 5,0	77	10,6	6,3 ~ 7,2	49,85 €
20,0 x 6,3	80	13,2	8,0 ~ 8,9	69,31 €

Avec chanfrein et bourrelet de renfort With chamfer and reinforcing bulge

Con chaflan y refuerzo

Con smusso e bordino di rinforzo

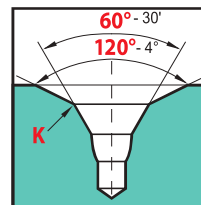

Emballage Packaging
Embalaje Imballo

magafor 023-14

10 pièces piezas pezzi D x d ≤ 10 x 4

magafor 145

10 pièces piezas pezzi N° 1W ~ 5W

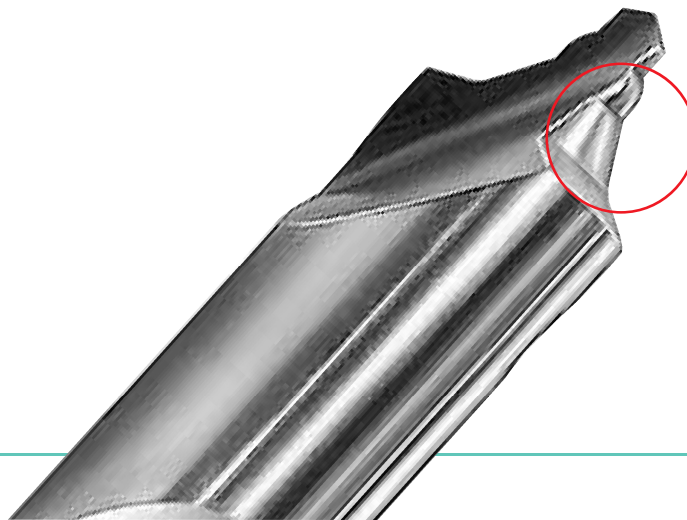

Centrage • Pointage / Centering • Spotting
Centratura • Centrate NC / Centrato • Punteado