



Pour moulistes

For moulds

Para moldistas

Per stampisti

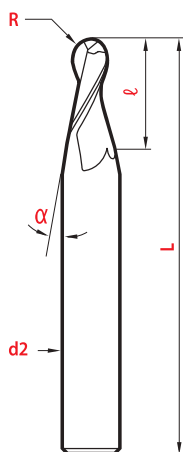
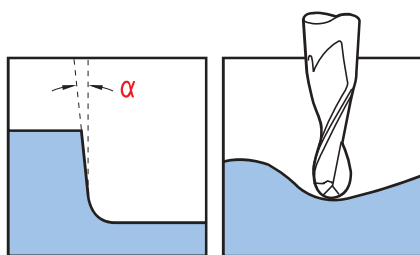

$\ell = 8 \times R$

CARBURE CARBIDE
Metallo duro



R ± 0,01	L	ℓ h10	α d2 h5	1°	1° 30'	2°
				magaforce 8501	magaforce 8503	magaforce 8505
0,5	39	4	3	70,13 €	70,13 €	70,13 €
0,75	39	6	3	72,57 €	72,57 €	72,57 €
1,0	39	8	3	76,21 €	76,21 €	76,21 €
1,25	44	10	4	96,88 €	96,88 €	96,88 €
1,5	44	12	4	99,32 €	99,32 €	99,32 €
2,0	52	16	5	101,75 €	101,75 €	101,75 €



$\ell = 12 \times R$

CARBURE CARBIDE
Metallo duro



R ± 0,01	L	ℓ h10	α d2 h5	1°	1° 30'	2°
				magaforce 8502	magaforce 8504	magaforce 8506
1,0	50	12	4	104,19 €	104,19 €	104,19 €
1,5	60	18	5	118,78 €	118,78 €	118,78 €
2,0	75	24	6	130,94 €	130,94 €	130,94 €



D = d2

CARBURE CARBIDE
Metallo duro



D	L	ℓ	d2	R	Hard'X 8549-H
h11		+ 0,5	h5	± 0,01	
1,0	50	1,5	1,0	0,5	75,40 €
1,5	50	2,25	1,5	0,75	70,54 €
2,0	50	3,0	2,0	1,0	66,89 €
2,5	50	3,75	2,5	1,25	70,54 €
3,0	50	4,5	3,0	1,5	75,40 €

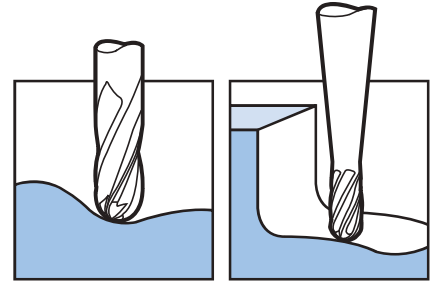

L = 150

CARBURE CARBIDE
Metallo duro



D	ℓ1	ℓ2	α	R	Hard'X 8569-H
h11	+ 0,5	+ 0,5	α	± 0,01	
3,0	4,5	60	1° 30'	1,5	145,94 €
4,0	6,0	60	1°	2,0	148,37 €
5,0	7,5	60	30'	2,5	150,81 €
6,0	9,0	-	-	3,0	155,67 €

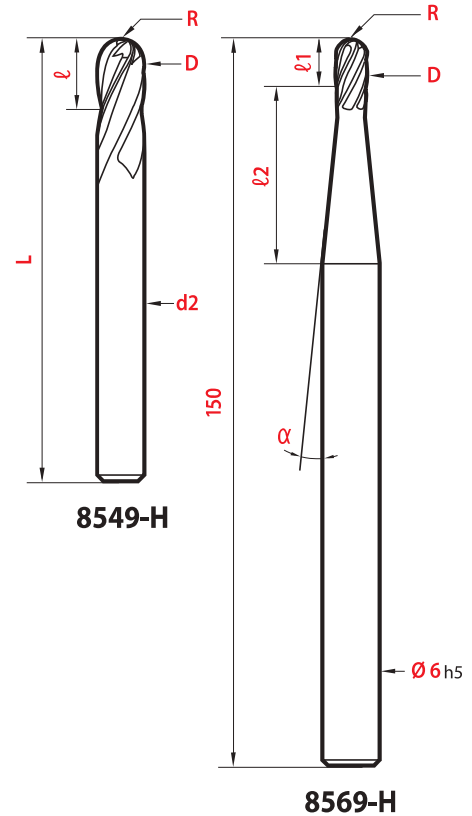

Super finish

"Multidents" super finition (moins de vibrations), durée de vie de l'outil prolongée et profil préservé.

"Multiflutes" for super finish (less vibrations), extended tool-life and preserved shape.

"Multilabios" para super acabados (menos vibraciones), prolongación de la vida útil de la herramienta y conservación del perfil.

"Multi-denti" super finitura (minori vibrazioni),

maggior durata dell'utensile e mantenimento del profilo.